

## Advanced roll cladding solutions



Welding Alloys design and manufacture a range of cored welding wires, bringing a solution to all roll wear problems

### Wear phenomena for continuous casting rolls

Fluctuating roll temperature, water spray, low pH levels and abrasion all lead to harsh conditions for continuous casting rolls.

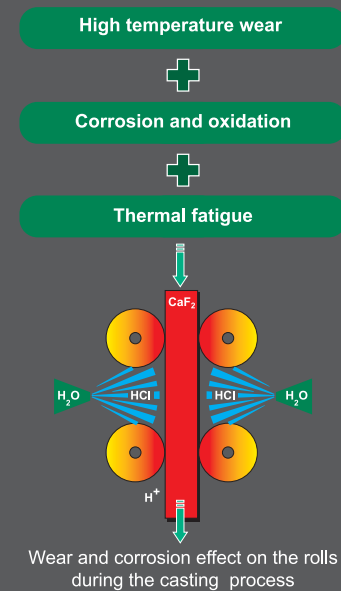

Wear and corrosion effect on the rolls during the casting process

### WA Cored Wire

Welding Alloys' nitrogen-containing wires have been developed to produce an almost fully martensitic weld structure with controlled delta-ferrite level.

Alloying conditions such as Cr Mo Ni and N are optimised to achieve maximum corrosion and oxidation resistance – pitting resistance index exceeding 20.

High temperature wear resistance, micro-structural stability and mechanical properties are optimised by micro-alloying and grain refinement.

#### Production process

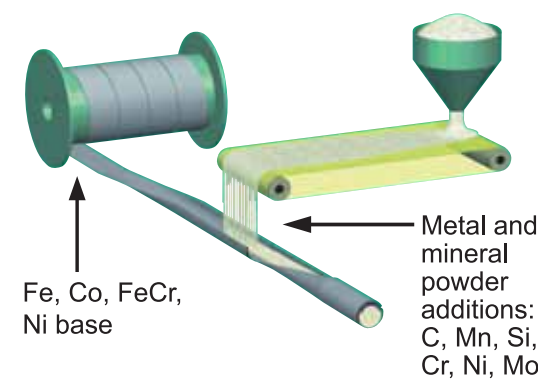

Welding Alloys produce cored welding wire which is segregation free, and a precisely controlled powder-to-strip ratio is achieved. The finish and weldability are consistently excellent, ensuring a reliable weld deposit.

#### Welding processes Product types

- Open arc
- Submerged arc
- Gas shielded

- Rebuilding wire
- Buffering wire
- Cladding wire



## A perfectly controlled technology



**WA Cored Wires™**  
Design and manufacture of all types of cored welding wires

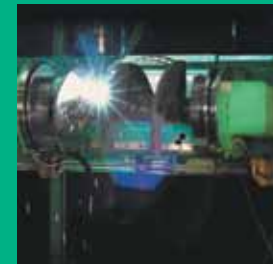

**WA MultiSurfacer™**  
Design and manufacture of automated welding equipment for hardfacing and rebuilding applications



**WA Integra™ Services**  
Innovative hardfacing and rebuilding solutions by welding



## A worldwide presence

<b>United Kingdom</b> (Head office) Welding Alloys Ltd	<b>Greece</b> Welding Alloys Hellas EPE	<b>South Africa</b> WASA (PTY) Ltd
<b>Argentina</b> Welding Alloys Argentina S.A.	<b>India</b> Welding Alloys South Asia Pvt Ltd	<b>South Korea</b> Welding Alloys Korea Ltd
<b>Australia (Trading Partner)</b> Specialised Welding Products Pty Ltd	<b>Iran</b> Aliaj Joosh Iran	<b>Spain</b> Welding Alloys España
<b>Brazil</b> Welding Alloys Brasil Ltda	<b>Italy</b> Welding Alloys Italiana s.r.l.	<b>Sweden</b> Welding Alloys Sweden
<b>China</b> Welding Alloys China Ltd	<b>Japan</b> Welding Alloys Japan	<b>Thailand</b> Welding Alloys (Thailand) Co. Ltd
<b>Egypt</b> Welding Alloys Egypt	<b>Malaysia</b> Welding Alloys (Far East) Sdn. Bhd.	<b>Turkey</b> Welding Alloys Limited Şirketi
<b>Finland</b> Welding Alloys Finland Oy	<b>Mexico</b> Welding Alloys Panamericana S.A. de C.V.	<b>Ukraine</b> Welding Alloys Ukraine
<b>France</b> Welding Alloys France SAS	<b>Morocco</b> Welding Alloys Maroc Sarl	<b>United Arab Emirates</b> Welding Alloys Middle East FZC
<b>Germany</b> Welding Alloys Deutschland GmbH	<b>Poland</b> Welding Alloys Polska Sp. z o.o.	<b>USA</b> Welding Alloys (USA) Inc.
	<b>Russia</b> ZAO Welding Alloys	<b>Vietnam</b> Welding Alloys Vietnam Co. Ltd.

[www.welding-alloys.com](http://www.welding-alloys.com)



**Continuous Casting**  
Advanced roll cladding solutions

## Advanced roll cladding solutions

### WA Total Solution

The Welding Alloys Group, founded in 1966, specialises in the design and manufacture of highly alloyed cored wires and automated welding equipment for surfacing applications.

As a result of our long term commitment to research and development, we have unique expertise in continuous casting roll cladding technology. Understanding the service conditions of continuous casting rolls has enabled us to develop specific laboratory tests in order to develop new products. Welding Alloys has revolutionised roll cladding and pioneered the development of nitrogen-containing materials. We have a programme of continuous research and improvement, bringing the latest technology to industry.

Welding Alloys has forged partnerships in the steel industry for many years with steel producers, equipment manufacturers and contractors, which ensures our experience in the technical advances required by the steel industry today.

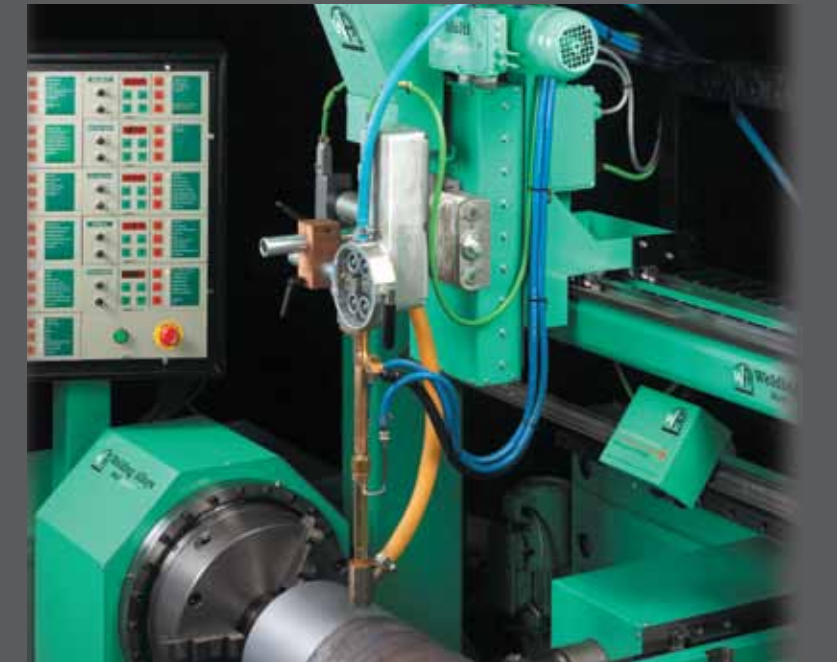

the global  
solution supplier



## Technical expertise



### Research and development is at the heart of the Welding Alloys Group

- Technical advancements from our laboratories and workshops
- Partnerships with steelworks, OEMs and engineering services
- Co-operation with technical universities, welding and research institutes

### Alloy design and manufacture

We employ metallurgists, material scientists and engineers who continuously research and develop materials to combat wear, oxidation and corrosion and high temperature fatigue.

The failure mechanisms of materials are investigated to generate advanced solutions.

As an example, the chemical composition of martensitic stainless steels is optimised to control the delta ferrite level, and to improve the high temperature mechanical properties and corrosion resistance.

Welding Alloys has specifically developed:

- Filler metal for open-arc welding
- Low carbon nitrogen-containing cladding
- Highly temperature and corrosion resistant superalloys for top zone rolls
- Super-austenitic alloys for casting rolls exposed to magnetic fields

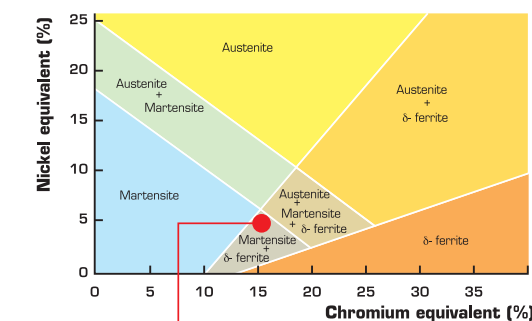

Making our customers masters of continuous casting roll cladding technology

## WA MultiSurfacer

### Automated welding equipment

Our Roll Surfacer range of automated welding equipment is designed and manufactured specifically for cladding continuous casting rolls



### High productivity

WA MultiSurfacer - Highly automated welding equipment with multi-functionality:

- single or twin-wire welding head
- single or multiple welding heads
- single or multiple stations

Flexible equipment and easy to programme digital control box requires minimum intervention, resulting in maximised arc time - designed and manufactured to exactly suit the customer's needs

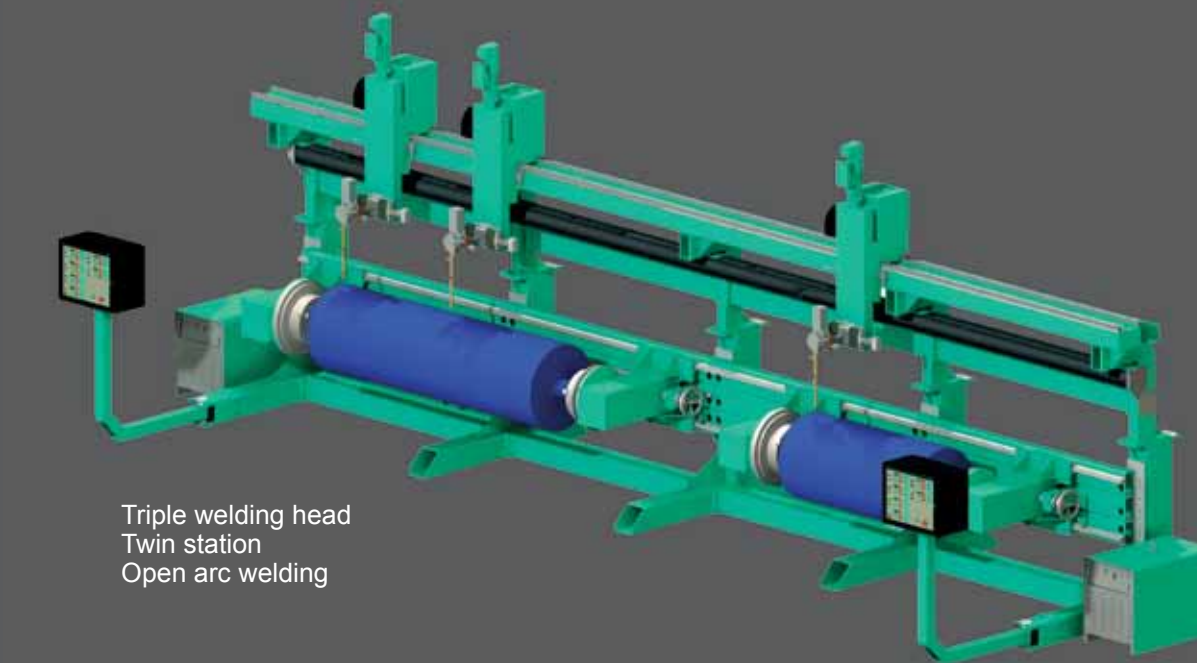

Triple welding head  
Twin station  
Open arc welding

WA MultiSurfacer SCM

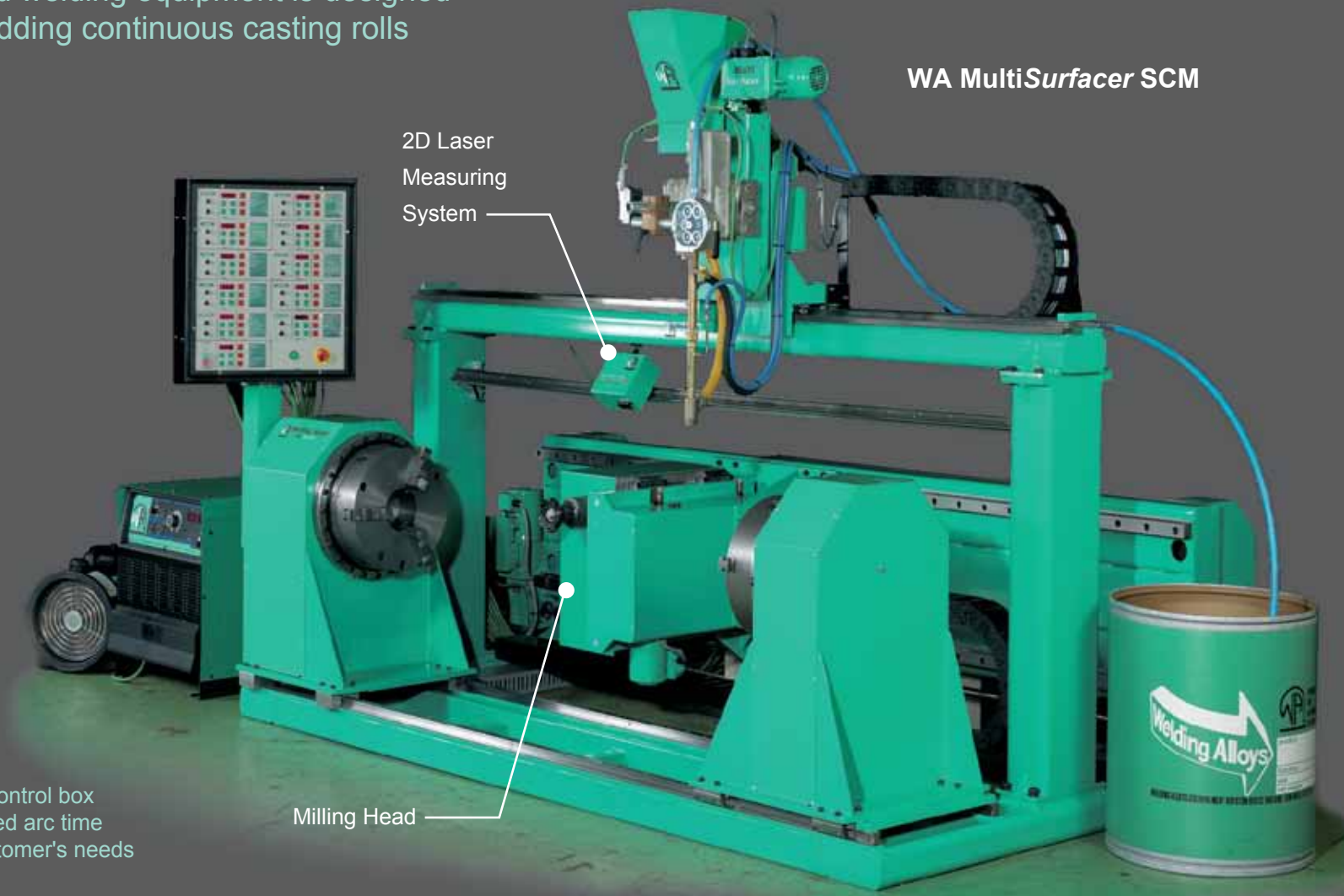

2D Laser Measuring System

Milling Head



### Ground-breaking technology

One example of our cutting edge design is the multi-functional WA MultiSurfacer SCM

### All-in-one: Scanning - Cladding - Machining

- Incorporated milling head allows machining whilst welding
- 2D Laser Measuring System gives constant monitoring of component size

### Adaptability

Flexibility for varying welding processes

- Open arc: universal process
- Submerged arc: recommended for large rolls
- Gas shielded: used for special alloys

Designed for welding rolls of all dimensions

Quick-lock grip system which allows expansion and contraction of rolls during welding

### Weld quality - consistently high

Smooth "as-welded" surface requiring reduced machining

Defect free

Precise and continuous control of welding parameters:

- Inverter control
- Application-specific programming
- Restricting process errors
- Multi-axis synchronisation

Reproducibility

### Health and safety checklist

- Our equipment complies with the latest health and safety regulations
- Operator protection against arc and fume exposure

## The WA commitment to long-term partnership

### Welding Alloys has developed successful partnerships with:

- Steel manufacturers
- OEMs
- Sub-contractors

### We can provide:

- Global supply and service contract for steel groups
- Technology transfer agreement
- Licence agreement
- Joint venture initiatives
- Financing

### Scandinavian steelworks gain massive cost benefits from our process and products

Following site visits to Welding Alloys refurbishment activities in Finland, a large Swedish steelworks decided to change their processing in the hope of significantly reducing their roll maintenance costs.

Originally using conventional roll cladding techniques, operating welding equipment on two shifts, limited roll life was realised. By adopting Welding Alloys technology, products and process expertise to their business, the steel manufacturer is now able to maintain significantly high quality roll refurbishment, with only one shift.

Roll life has dramatically increased - consistently by three times, resulting in soaring productivity and major cost savings for the business.



### Technology Transfer - Middle East

Welding Alloys Group was approached by a potential customer who required a dedicated roll shop facility, at a steel manufacturing plant.

Our technicians and engineers carried out an extensive feasibility study and closely examined the roll performance and reliability.

Based on that analysis, Welding Alloys proposed specifications for the production layout and equipment requirements. Our technicians established welding procedures specific to that site and to the customers exacting requirements, and supplied suitable equipment and consumables. In addition, we introduced quality assurance and training programmes for personnel.

The creation of this facility is a considerable advantage to the business - but the real benefit comes from the procedures that Welding Alloys were instrumental in implementing.



### Joint venture with a steel producer in China

Successfully formed almost a decade ago, Welding Alloys has a joint partnership with a large Chinese steel manufacturer in the Benxi province.

The partnership operates as a sub-contractor to the steel plant, welding rolls for the plants' continuous casting lines. Welding Alloys' products are used exclusively in the welding/cladding activity, which was established using our state-of-the-art equipment and know-how.

The feedback from the steel plant is that they have significantly improved the service life of the continuous casting rolls.